

2-hr. Fire Rated Wall Construction Overview



County of Henrico Building Inspections

For 2021 VRC and 2021 VCC building code

[Orig. 5/11] [Rev. 7/15] [Rev. 9/19] [Rev. 7/22] [Rev. 5/25]

Table of Contents

1. List of common 2-hr. rated walls
 2. What are the major differences between the six manufacturer's 2-hr. rated walls?
 3. What exactly gives you the 2-hr. rating in a rated wall?
 4. Maintaining the $\frac{3}{4}$ " air gap for the U347 wall
 5. Wall clips
 6. Fireblocking between the floor joist and the 2-hr. rated wall
 7. Stand-up showers/bathtubs adjacent to the rated wall
 8. Mix-and-matching shaft liners from different manufacturers in a rated wall
 9. Tradesmen's work located in the rated assembly
 10. Installing a vapor barrier between the $\frac{1}{2}$ " gyp. and stud wall framing
 11. Protecting the fire-rated wall in attic and/or crawlspaces
 12. Attaching siding/brick veneer at roof/wall offsets
 13. Exterior vented soffits (under roof overhangs) adjacent to the rated wall
 14. Using faced or unfaced batt insulation in the walls
 15. STC ratings
- Appendix: A) Firewall Comparisons
- B) Construction Methods at Offsets

1. List of common 2-hr. rated walls

U336 - USG

U366 - Certainteed

U347 - National Gypsum

U388 - Certainteed

U373 - Georgia Pacific

U375 - American Gypsum

* The first 2-hr area separation wall was the U336 (created in 1964). Use of an area separation wall did not gain traction in the construction industry until the MGM Grand fire in 1980.

2. What are the major differences between the six manufacturer's 2-hr rated walls?

- Maximum wall height permitted for the rated wall
- Optional use of steel studs in lieu of wood studs
- Fastening schedule of $\frac{1}{2}$ " gypsum to stud wall
- Wall clip spacing
- The shaft liner is produced by a specific manufacturer and is thus specific to the manufacturer's 2-hr. rated wall

See attached "Firewall Comparisons" document in Appendix A.

3. What exactly gives you the 2-hr. rating in a rated wall?

The two layers of 1" gypsum shaft liner provides the 2 hour rating, and maintaining the $\frac{3}{4}$ " air gap is as important as the 2 hour rated wall (National Gypsum's representative says the shaft liner and the $\frac{3}{4}$ " air gap is the "rated

assembly".) Beyond the $\frac{3}{4}$ " air gap, the wood stud wall, the $\frac{1}{2}$ " layer of gypsum on the outside of the wall, and any insulation (mineral or fiberglass) in the stud wall cavity is not as critical.

Side note: The $\frac{3}{4}$ " air gap is also important to achieve a specified STC sound rating.

4. Maintaining the $\frac{3}{4}$ " air gap for the U347 wall

For National Gypsum's 2-hr. rated wall, if the $\frac{3}{4}$ " air gap cannot be maintained between the H-stud and the wood stud wall (ie. the gap is **less** than $\frac{3}{4}$ "), then a $\frac{1}{2}$ " x 6" wide strip of Gold Bond Fire-Shield G gypsum wallboard may be screw-attached to the H-stud to provide a layer of protection.

If the $\frac{3}{4}$ " air gap cannot be maintained on another manufacturer's wall assembly (ie. USG, GP), we will allow the use of a strip of $\frac{1}{2}$ " Type X gypsum to be used on the H-studs in lieu of the $\frac{3}{4}$ " air gap.

5. Wall clips

Wall clips should be attached to the metal H-stud framing with 3/8" Type S pan head screws and attached to the wood stud with a 1 $\frac{1}{4}$ " Type W screw. One screw is required in the H-stud and one screw in the wood stud. The extra holes in the clip are there for when a hole does not line up with a stud, and thus you can choose another hole in the clip that does line up with the stud to secure the clip to. The clip may be manipulated (ie. bent, straightened, added on to, etc.) to connect the stud wall to the H-stud. Wall clips are to be spaced 24" O.C. horizontally max. (ie. one clip per H-stud).

6. Fireblocking between the floor joist and the 2-hr. rated wall

The manufacturers' literature for all of the 2-hr rated walls show fireblocking located between the floor joist and the rated wall for the full depth of the joist. The fireblocking does not necessarily have to extend the full depth of the joist. Fireblocking may be used to fill the gap at the top and bottom of the joist only. In fact, gypsum liner may be attached to the top plates and sole plate of the stud wall to prohibit the passage of flame between floors. The key here is to provide enough fireblocking so that the fire cannot proceed through the air gap between the floors.

If gypsum liner is used as fireblocking between the floors, the liner may rest on top of the wall clips. It does not necessarily have to be fastened in any way. Any remaining gaps left after the liner is installed can be filled with mineral wool.

7. Stand-up showers/bathtubs adjacent to the rated wall

$\frac{1}{2}$ " gypsum is not required to be located between the shower/bathtub and the stud wall of the fire rated assembly. Also, insulation is not required to be installed behind the tub as well (unless required for an STC rating). **The purpose of the $\frac{1}{2}$ " gypsum is to provide a layer of protection for the shaft liner. Any material could be used to provide protection, including a fiberglass shower stall or wood sheathing.**

8. Mix-and-matching shaft liners from different manufacturers in a rated wall

Using another manufacturer's shaft liner in a rated wall is PROHIBITED. An example would be using a USG shaft liner in a National Gypsum rated wall

assembly or using a generic, unmarked shaft liner in a rated wall assembly.

The USG and National Gypsum representatives both gave the same reason: In the event of a fire, if the 2 hr. rated wall does not perform as it should have, then no manufacturer will accept responsibility. If the builder mix-and-matches shaft liners from various manufacturers, then the builder will need to contact our building official to resolve the issue. If the builder uses a different manufacturer's shaft liner *entirely* in a rated wall assembly the builder may be able to resubmit the correct manufacturer's rated wall construction details to the plan reviewer for approval if the wall can be made to comply with the new details.

For example, if a U347 wall by National Gypsum is what is shown on the approved plans, and a Georgia Pacific shaft liner was used in the rated wall assembly, the builder may be able to submit the construction details for Georgia Pacific's U373 wall assembly for approval, provided that the rated wall is no taller than 44 ft (as opposed to the 66 ft max. height allowed by U347).

The rated wall that is shown on the approved plans is what will be expected to be built in the field.

It should be noted that the $\frac{1}{2}$ " gypsum required on the wood stud wall of a 2-hr. rated assembly may come from any manufacturer since the $\frac{1}{2}$ " gypsum isn't an integral part of the rated wall assembly. Furthermore, all six manufacturers of the 2-hr. rated wall do not specify a specific brand of $\frac{1}{2}$ " gypsum to be used here.

On the other hand, if any 1-hr. rated walls are to be used (ie. at wall offsets), refer to the UL listing for the 1-hr. rated wall to see if the gypsum that is required on the stud wall needs to be from a specific manufacturer, as the gypsum here is an integral part of the fire rated

assembly. Many 1-hr. rated wall assemblies listed in UL will allow gypsum from most major manufacturers to be used.

9. Tradesmen's work located in the 2-hr. rated assembly

* REVISED * - The 2009 VRC now states that plumbing or mechanical equipment, ducts, and vents shall not be permitted in the rated wall assembly. Electrical wiring is permitted in accordance with Chapters 34 through 43. Electrical outlet boxes are to be installed per R302.4. (See R302.2 Exception, current section is now R302.2.2).

* REVISED * - The 2018 VRC now states that water-filled sprinkler piping may be located in the rated wall assembly (See R302.4.1 Exception 2).

There are no concerns with running electrical wire in the $\frac{3}{4}$ " air gap between the shaft liner and the wood stud wall. Per USG's representative, there is not much difference running the wire behind the stud wall or running it through the studs since the studs are a combustible material anyway. Again, the key here is that the two layers of 1" gypsum shaft liner provides the 2-hour rating, along with maintaining the $\frac{3}{4}$ " air space. Materials located beyond the air space are not as critical.

10. Installing an air barrier between the $\frac{1}{2}$ " gyp. and stud wall framing

The 2018 VRC requires an air barrier to be installed between the $\frac{1}{2}$ " gypsum and stud wall framing in various locations. Would this have an adverse effect on the wall rating if an air barrier is installed within the 2-hr rated assembly?

Both representatives from National Gypsum and USG did not express an

issue with this. And in a letter from Underwriters Laboratories to USG (dated 2/18/2011), UL stated that a vapor barrier located within the rated assembly would not have an adverse effect on the rated wall's performance as the vapor barrier would char away rather quickly.

11. Protecting the fire-rated wall in attic and/or crawlspaces

Each of the manufacturers' literature on 2-hr. rated walls do show a level of protection for the shaft liner in the attic or crawlspace, usually accomplished with a stud wall covered with a $\frac{1}{2}$ " layer of gypsum. Additionally, the U347 offers five other options (listed under item 6 in the UL listing) in lieu of using a stud wall covered with $\frac{1}{2}$ " gypsum, one of which includes attaching a $\frac{1}{2}$ " x 6" gypsum strip to the H-stud.

The issue here is this: If a townhouse is on fire, the H-stud supporting the shaft liner between a burning townhouse and a non-burning townhouse will get hot. If anything in the attic of the non-burning unit is touching the H-stud, then a fire could start in the non-burning unit.

We will enforce a layer of protection for the H-stud in the attic or crawlspace. The preferred option will be to attach a $\frac{1}{2}$ " x 6" strip of gypsum to the H-stud. A stud wall with $\frac{1}{2}$ " gypsum (such as what the manufacturer's literature shows) can be used as well. Another option could be to attach OSB to the face of the last truss that occurs before the fire rated wall. All we're doing is providing a layer of protection for the H-stud.

12. Attaching siding/brick veneer at roof/wall offsets

The manufacturers' literature is not necessarily clear on how to attach siding/brick veneer at roof/wall offsets. The USG and National Gypsum representatives have both stated that vinyl siding may be attached to the

shaft liner wall, but brick veneer cannot be attached. For vinyl siding, OSB sheathing may be placed over the shaft liner and fastened to the H-studs. Then, a vapor barrier and vinyl siding may be attached to the sheathing. For brick veneer, no easy solution was provided by either manufacturer because they don't want the brick to be attached directly to the shaft liner.

See "Construction Methods at Offsets" in Appendix B. The County will allow the following details to be used when attaching siding/brick veneer at roof/wall offsets.

13. Exterior vented soffits (under roof overhangs) adjacent to the rated wall

* REVISED * - The 2015 VRC now has prescriptive considerations for roof overhangs that occur where fire separation distances are less than 5 feet (see Table R302.1(1), footnotes "a" and "b").

14. Using faced or unfaced batt insulation in the walls

There is no problem with using faced or unfaced batt insulation in the walls for achieving an R-value or STC rating.

15. STC sound ratings

Most of the 2-hr rated walls have STC testing data that are fairly similar to one another. Some have been tested with fiberglass only, some with mineral wool only, and some with both fiberglass and mineral wool. The minimum STC code requirement for a wall between units is 45 (USG's 2-hr).

rated wall is a 46 without insulation and National Gypsum's 2-hr. rated wall is a 50 without insulation). A fairly common subdivision STC proffer is 54.

To avoid confusion, we will use the following guideline:

- A 2-hr. rated wall without insulation has an STC rating of at least 45, which is the minimum code requirement.
- A 2-hr. rated wall with 3 ½" of insulation (mineral wool or fiberglass) on one side of the wall will have an STC rating of at least 55.
- A 2-hr. rated wall with 3 ½" of insulation (mineral wool or fiberglass) on both sides of the wall will have an STC rating of at least 61.

Since 54 is a common STC proffer, it doesn't matter if one manufacturer's wall will get you a 55 and another will get you 57 by using insulation on one side of the wall. Both walls still exceed the STC proffer requirement.

End of document

There is an extended version of this document, including explanations and notes from the manufacturer's representatives, as well as support documentation for the information above. This document was compiled using the various manufacturers' 2-hr. rated wall literature, meetings conducted with the County of Henrico and USG and National Gypsum, and support documentation provided by Underwriters Laboratories.

[Document originally created in 2011 under the 2009 VRC. Revisions have been made to be up-to-date with the current code cycle.]

Appendix A

FIREWALL COMPARISONS				
	U336 (USG)	U347 (National Gypsum)	U373 (Georgia Pacific)	U366 (CertainTeed)
Max. wall height	66 ft.	66 ft. (54 ft. if batt and blanket option used in lieu of 1/2" gypsum)	44 ft.	70 ft.
C-channel (ie. Floor, intermediate, or top wall) (Also referred to as "steel track")	No. 25 MSG galv. steel, 2" wide channel w/ 1" long legs, fastened with suitable fasteners at 24" O.C.	No. 25 MSG galv. steel, 2" wide channel w/ 1" long legs, fastened with suitable fasteners at 24" O.C.	No. 25 MSG galv. steel, 2 3/16" wide channel w/ 1" long legs, fastened with suitable fasteners at 24" O.C.	No. 25 MSG galv. steel, 2" wide channel w/ 1" long legs, fastened with suitable fasteners at 24" O.C.
H-studs (ie. Metal studs)	No. 25 MSG galv. steel, H-shaped flange, 2" depth, 1 3/8" flange width, spaced at 24" O.C.	No. 25 MSG galv. steel, H-shaped flange, 2" depth, 1 3/8" flange width	No. 25 MSG galv. steel, H-shaped flange, 2 1/8" depth, 1 1/2" flange width, spaced at 24" O.C.	No. 25 MSG galv. steel, H-shaped flange, 2" depth, 1 3/8" flange width, fasteners at 24" O.C.
Wood stud wall	2x4, max. spacing 24" O.C., cross braced at mid-height for clip attachment (if needed), min. 3/4" separation between wood framing and shaftliner, bearing or non-bearing wall	2x4, max. spacing 24" O.C., cross braced at mid-height for clip attachment (if needed), min. 3/4" separation between wood framing and shaftliner, bearing or non-bearing wall	2x4, max. spacing 24" O.C., cross braced at mid-height for clip attachment (if needed), min. 3/4" separation between wood framing and shaftliner, bearing or non-bearing wall	2x4, max. spacing 24" O.C., cross braced at mid-height for clip attachment (if needed), min. 3/4" separation between wood framing and shaftliner, bearing or non-bearing wall
Shaftliner	2 layers of 1" thick gyp. liner panels, 24" width, vert. edges are friction fit into steel studs, using USG Type SLX panels CGC Inc. Type SLX panels	2 layers of 1" thick gyp. liner panels, 24" width, vert. edges are friction fit into steel studs, using National Gyp. Type FSW, FSW-B, or FSW-7 panels (ie. This is Gold Bond brand Fire Shield)	2 layers of 1" thick gyp. liner panels, 24" width, vert. edges are friction fit into steel studs, using GP Types TRSL or DGUSL panels	2 layers of 1" thick gyp. liner panels, 24" width, vert. edges are friction fit into steel studs, using CertainTeed ProRoc Shaftliner, EGRG Shaftliner, GlasRoc Shaftliner, LGFCSL
1/2" gypsum board	Rated or non-rated, min 1/2" thick, 4 ft. wide, applied horiz. or vert., attached to studs w/ 1 1/4" long steel drywall nails spaced 8" O.C. Vert. joints located over studs Optional: joints covered w/ paper tape, nail heads covered with joint compound.	Rated or non-rated, min 1/2" thick, 4 ft. wide, applied horiz. or vert., attached to studs w/ 1 1/4" long steel drywall nails spaced 12" O.C. (for wood stud wall framing) If steel studs used in lieu of wood, use 1" long Type S steel screw spaced 12" O.C.) Vert. joints located over studs Horiz. joints to be butted tight to form a closed joint. Optional: joints covered w/ paper tape, nail heads covered with joint compound.	Rated or non-rated, min 1/2" thick, 4 ft. wide, applied horiz. or vert., attached to studs w/ 1 1/4" long steel drywall nails spaced 12" O.C. (for wood stud wall framing) If steel studs used in lieu of wood, use 1" long Type S steel screw spaced 12" O.C.) Vert. joints located over studs Optional: joints covered w/ paper tape, nail heads covered with joint compound.	Rated or non-rated, min 1/2" thick, 4 ft. wide, applied horiz. or vert., attached to studs w/ 1 1/4" long steel drywall nails spaced 8" O.C. Vert. joints located over studs Horiz. joints to be butted tight to form a closed joint. Optional: joints covered w/ paper tape, nail heads covered with joint compound.
3 alternatives to using 1/2" gypsum board: 1) Plywood or OSB sheathing 2) Batts and blankets 3) Wall and partition facing	In a UL letter to USG (dated 8/17/05), UL says that the 1/2" gypsum board is merely a protective barrier for the shaft liner and that other materials could be used for protection, including plywood, OSB, and fiberglass insulation, especially in areas such as attics where the barrier isn't subjected to abuse.	Min. 1/2" thick plywood or OSB, applied horiz. or vert. to wood or steel studs. Vert joints located over studs, horiz. joints butted tight, fastened to studs with nails or screws of adequate length, spaced 12" O.C. Fiberglass or mineral wool, 3 1/2" thick, completely fill the wood or steel stud cavity, aluminum clips shall be spaced max. 5 ft. O.C. vertically, insulation must meet UL BKNV (which is FHC 25/50) or BZJZ. 4ft. wide panels applied vert. Panels attached to wood studs w/ 1 5/8" long steel drywall screws, spaced 16" O.C., Vert. joints located over studs, joints covered w/ tape or mud.	Min. 1/2" thick plywood or OSB, applied horiz. or vert. to wood or steel studs. Vert joints located over studs, horiz. joints butted tight, fastened to studs with nails or screws of adequate length, spaced 12" O.C. Fiberglass or mineral wool, placed in stud cavities, max. 3.0 pcf density, insulation must meet UL BKNV (which is FHC 25/50) or BZJZ. 4ft. wide panels applied vert. Panels attached to wood studs w/ 1 5/8" long steel drywall screws, spaced 16" O.C., Vert. joints located over studs, joints covered w/ tape or mud.	Min. 1/2" thick plywood or OSB, applied horiz. or vert. to wood or steel studs. Vert joints located over studs, horiz. joints butted tight, fastened to studs with nails or screws of adequate length, spaced 12" O.C. Fiberglass or mineral wool, 3 1/2" thick, completely fill the wood or steel stud cavity, insulation must meet UL BKNV (which is FHC 25/50) or BZJZ. 4ft. wide panels applied vert. Panels attached to wood studs w/ 1 5/8" long steel drywall screws, spaced 16" O.C., Vert. joints located over studs, joints covered w/ tape or mud.
Attachment clips	Aluminum angle, 0.063" thick, 2" wide, 2" and 2 1/4" wide legs, secured with Type S screws, 3/8" long to H studs and Type W screws 1 1/4" long to wood framing	Aluminum angle, 0.049" thick, 2" wide, 2" and 2 1/4" wide legs, secured with Type S screws, 3/8" long to H studs and Type W screws 1 1/4" long to wood framing	Aluminum angle, 0.062" thick, 2" wide, 2" and 2 1/4" wide legs, secured with Type S screws, 3/8" long to H studs and Type W screws 1 1/4" long to wood framing	Aluminum angle, 0.063" thick, 2" wide, 2" and 2 1/4" wide legs, secured with Type S screws, 3/8" long to H studs and Type W screws 1 1/4" long to wood framing
Clip spacing	For walls up to 23 feet tall: Spaced 10 ft. O.C. max vertically For walls up to 44 feet tall: Spaced 10 ft. O.C. for upper 24 ft. and 5 ft. O.C. for remaining wall area below For walls up to 66 feet tall: Spaced 10 ft. O.C. for upper 24 ft., 5 ft. O.C. for the next 20 ft. in the middle, and 40" O.C. for remaining wall area below	For walls up to 23 feet tall: Spaced 10 ft. O.C. max vertically For walls up to 54 feet tall: Spaced 10 ft. O.C. for upper 24 ft. and 5 ft. O.C. for remaining wall area below For walls up to 66 feet tall: Spaced 10 ft. O.C. for upper 24 ft., 5 ft. O.C. for the next 30 ft. in the middle, and 39" O.C. for remaining wall area below	For walls up to 23 feet tall: Spaced 10 ft. O.C. max vertically For walls up to 44 feet tall: Spaced 10 ft. O.C. for upper 24 ft. and 5 ft. O.C. for remaining wall area below	For walls up to 23 feet tall: Spaced 10 ft. O.C. max vertically For walls up to 70 feet tall: Spaced 10 ft. O.C. for upper 24 ft. and 5 ft. O.C. for remaining wall area below
Non-bearing wall partition intersection (ie. where an interior wall frames perpendicularly into the rated wall)	Permitted, see 7 in UL U336 for construction details (same detail as U347 and U366)	Permitted, see 9 in UL U347 for construction details (same detail as U336 and U366)	(Not mentioned in UL U373, but we will allow it)	Permitted, see 7 in UL U366 for construction details (same detail as U336 and U347)
STC ratings:	2-hour rated wall as is, no insul. 2" mineral wool on one side 3" mineral wool on one side 2" mineral wool on both sides 3" mineral wool on both sides	2-hour rated wall as is, no insul. 3 1/2" mineral wool or fiberglass on one side 3 1/2" mineral wool or fiberglass on both sides	3 1/2" fiberglass insulation on both sides	3 1/2" fiberglass on both sides

Construction Methods for Fire Rated Walls at Wall and Roof Offsets

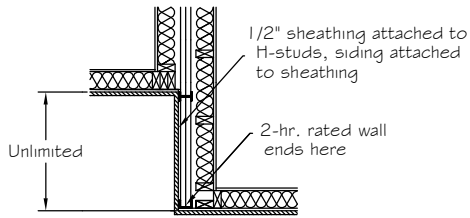

2-HR. Firewall wall offset with siding attachment

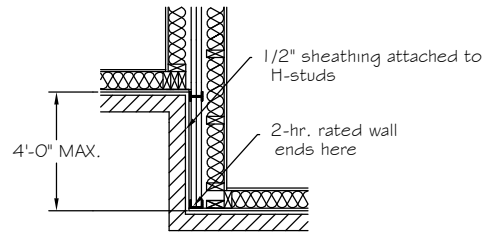

2-HR. Firewall wall offset with brick veneer attachment

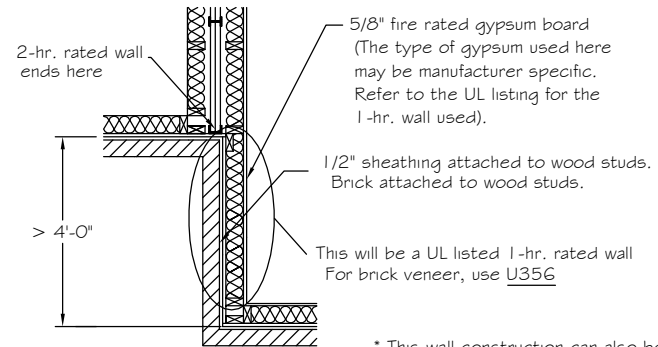

Wall offset using brick veneer when the offset exceeds 4'-0" in length *

* This wall construction can also be used for brick veneer when the wall offset is less than 4'-0" in length.

* This wall construction can also be used for siding for any length of wall offset.

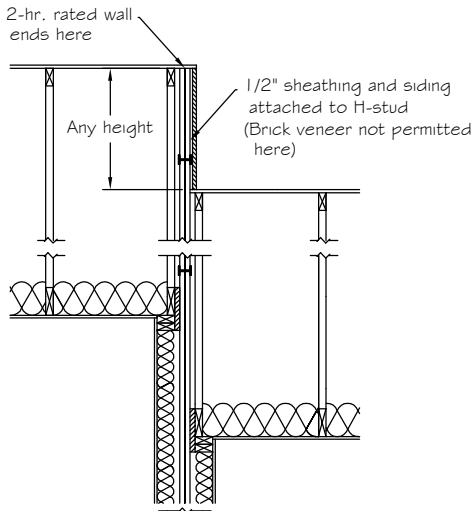

2-HR. Firewall roof offset with siding attachment

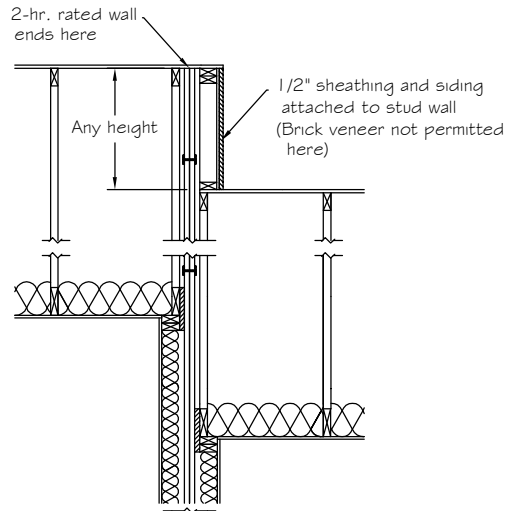

2-HR. Firewall roof offset with stud wall and siding attachment

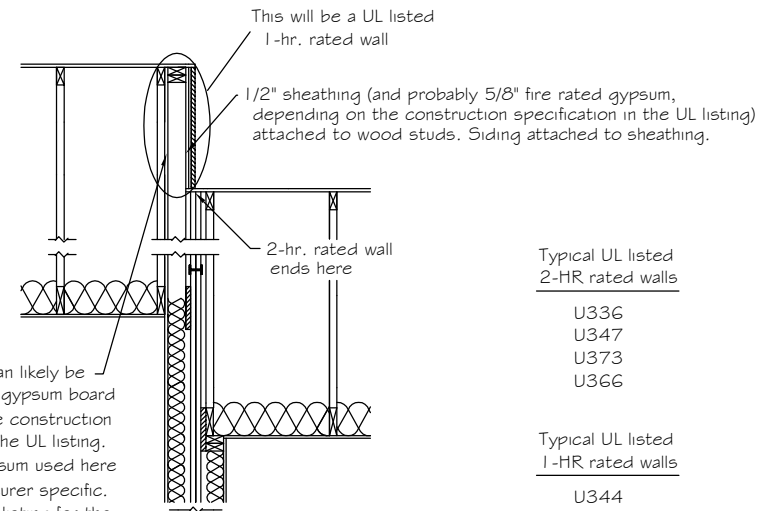

Roof offset using 1-HR. rated wall at offset

This will more than likely be a 5/8" fire rated gypsum board (depending on the construction specification in the UL listing). The type of gypsum used here may be manufacturer specific. Refer to the UL listing for the 1-hr. wall used).

Typical UL listed 2-HR rated walls

- U336
- U347
- U373
- U366

Typical UL listed 1-HR rated walls

- U344
- U305
- U355
- U356
- U357
- U359

